

Build
Your
Own

TWEETSIE®

RAILROAD

3-D

Mouse Mine #9 Engine

ASSEMBLY INSTRUCTIONS

Time to complete: Approx. 40 minutes • Difficulty level: Medium

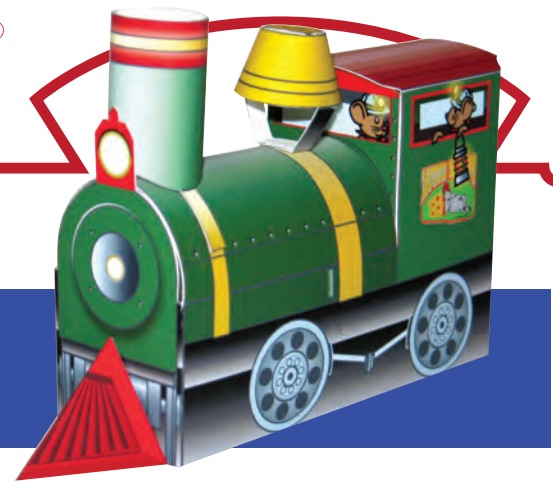

GET STARTED

materials:

- Metal-edged Ruler
- Glue (tacky craft glue or rubber cement)
- Butter knife (recommended)
- Scissors or craft knife (have an adult help)

1. Print out with a color desktop printer. Use "fit to page" option if needed, and set to maximum print area. Regular copy paper will work, heavier paper like card stock may work better.

2. Use scissors or a craft knife to cut out all the pieces along outer edges and where shown in pink. Have an adult help.

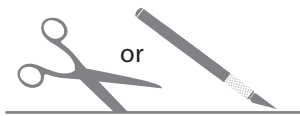

3. To help with folding, score all the pieces using the ruler for a guide and run the back side of the butter knife along the corner edges and tabs. Fold back all corners & tabs. (most all fold back to create a "peak" fold)

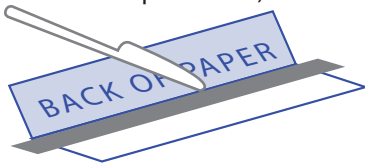

An example of a "peak" type fold.



An example of a "valley" type fold.



ASSEMBLY OF YOUR TRAIN

4. After everything is cut, scored & folded, start with the main body of the train. Begin with tab A & glue to edge A, then fold the front of cab & glue tab B to edge B. Proceed with steps C, D, E, etc.

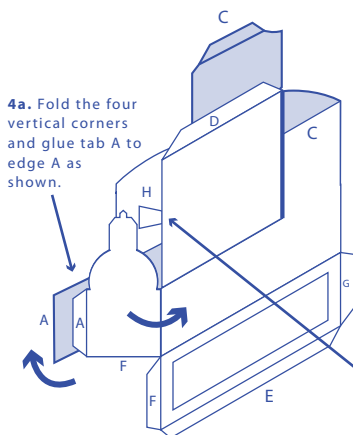

4a. Fold the four vertical corners and glue tab A to edge A as shown.

4b. Fold and bend the cab front tab B & glue to edge B.

4c. Fold and bend the cab roof around & glue tab C to edge C as shown.

4d. Bend the boiler top around and glue tab D to edge D as shown.

4e. Bend the tab H & glue behind front panel

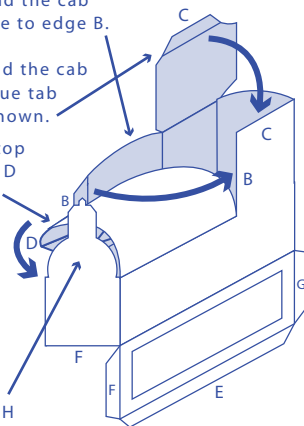

4h. Curve bell around & glue tab K. Fold down top of bell & glue tabs to the inside.

4i. Fold bell brackets as shown & glue bottom parts together K2. Then glue to Engine boiler. Refer to photo.

4g. Curve around smokestack & glue tab J to edge J.

note: It may be easier to pre-curl the stack & bell around a pen prior to gluing & attaching.

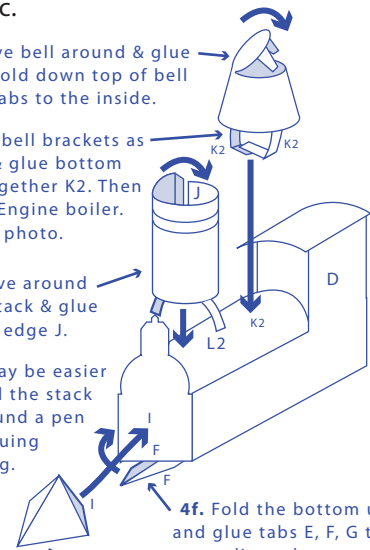

4f. Fold the bottom under and glue tabs E, F, G to the corresponding edges as shown.

4h. Fold the Pilot as shown & glue the two tabs to lower center of engine front.

